

Bearings / Wear Rings - "T" Profile

Technical details

Metric

Inch

Operating conditions

Maximum Speed 5.0 m/sec
Temperature Range -40°C + 120°C

15.0 ft/sec
-40°F + 250°F

Surface roughness

	µmRa	µmRt
Dynamic Sealing Face - Rod $\varnothing d_1$	0.4	4 max
Static Sealing Face - Rod $\varnothing D_2 L_1$	3.2 max	16 max
Dynamic Sealing Face - Piston $\varnothing d_1$	0.4	4 max
Static Sealing Face - Piston $\varnothing d_2 L_1$	3.2 max	16 max

	µinCLA	µinRMS
	16	18
	125 max	140 max
	16	18
	125 max	140 max

Housing Details & Tolerances

L_1 in
 r_1 in
Piston $\varnothing D_1$ in
 $\varnothing d_1$ in
 $\varnothing d_2$ in
 $\varnothing d_3$
See catalogue page for S & S2

L_1 in	+0.015 +0.010
r_1 in	0.016 max
Piston $\varnothing D_1$ in	H11
$\varnothing d_1$ in	D1 - G
$\varnothing d_2$ in	D1 - 2S1 +0.000 -0.004
$\varnothing d_3$	D1 - 2S2 +0.000 -0.004

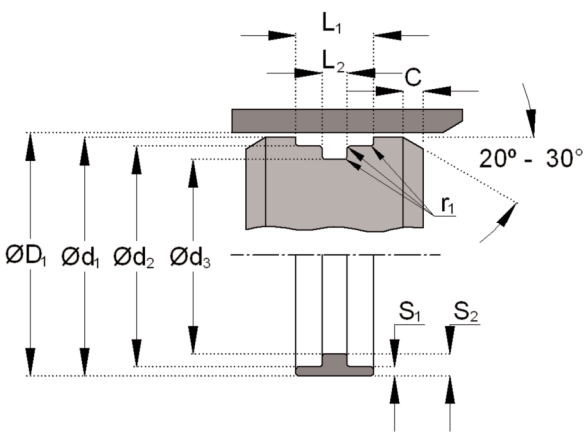

Design

The 533T Piston bearing is molded with 33% heat stabilized, glass reinforced Nylon 66. The design of the 533T is a "t-shape" cross section which allows full bearing contact while also offering the advantage of a t-groove form of retention that does not require side land near the working surface of the wear band.

The 533T is typically used in telescopic cylinder applications. It is not suitable for use in applications where water based fluids are used, nor is it suitable in applications where significant water is present, due to the swell of the nylon.

Features

- Moulded to size
- Easy installation
- Robust
- Long life
- Economical

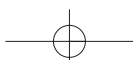

Bearings inch

533T

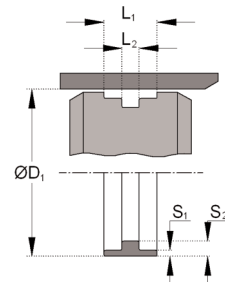

ØD1	S1	S2	L1 +/- .0025	L2 +/- .0025	ØD1 mm	S1 mm	S2 mm	L1 +/- .064	L2 +/- .051	PART No.
1.625	0.067	0.166	0.455	0.188	41.3	1.7	4.2	11.6	4.8	F30008
1.625	0.067	0.166	0.575	0.188	41.3	1.7	4.2	14.6	4.8	F30180
2.000	0.067	0.168	0.455	0.188	50.8	1.7	4.3	11.6	4.8	F30023
2.250	0.067	0.166	0.455	0.188	-57.2	1.7	4.2	11.6	4.8	F30034
2.750	0.067	0.164	0.583	0.188	69.9	1.7	4.2	14.8	4.8	F30053
3.000	0.067	0.156	0.583	0.188	76.2	1.7	4.0	14.8	4.8	F30065
4.000	0.067	0.156	0.583	0.188	101.6	1.7	4.0	14.8	4.8	F30103
4.500	0.067	0.131	0.763	0.243	114.3	1.7	3.3	19.4	6.2	F30119
5.500	0.067	0.131	0.763	0.243	139.7	1.7	3.3	19.4	6.2	F30139
6.000	0.067	0.156	0.643	0.253	152.4	1.7	4.0	16.3	6.4	F30146
6.500	0.067	0.131	0.763	0.243	165.1	1.7	3.3	19.4	6.2	F30156
7.500	0.067	0.131	0.763	0.243	190.5	1.7	3.3	19.4	6.2	F30164

