

## Piston Seals

### Technical details

#### Operating conditions

	Metric	Inch
Maximum Speed	0.5 m/sec	1.5 ft/sec
Temperature Range	-30°C +100°C	-22°F +212°F
Maximum Pressure	400 bar	6,000 p.s.i.



#### Maximum extrusion gap

	160	250	400
Pressure bar	160	250	400
Pressure p.s.i.	2400	3750	6000
Maximum Gap in	0.024	0.020	0.016

Figures show the maximum permissible gap all on one side using minimum clearance  $\emptyset$  and maximum bore  $\emptyset$ .

#### Surface roughness

	$\mu\text{mRa}$	$\mu\text{mRt}$	$\mu\text{inCLA}$	$\mu\text{inRMS}$
Dynamic Sealing Face $\emptyset D_1$	0.1 <> 0.4	4 max	4 <> 16	5 <> 18
Static Sealing Face $\emptyset d_1$ $\emptyset d_2$	1.6 max	10 max	63 max	70 max
Static Housing Faces $\emptyset d_3$ $L_1$ $L_2$	3.2 max	16 max	125 max	140 max

#### Chamfers & Radii

	0.187	0.250	0.375
Groove Section $\leq S$ in	0.187	0.250	0.375
Min Chamfer C in	0.156	0.187	0.250
Max Fillet Rad $r_1$ in	0.010	0.016	0.016
Max Fillet Rad $r_2$ in	0.010	0.016	0.016

#### Tolerances

	$\emptyset D_1$	$\emptyset d_1$	$\emptyset d_3$	$L_1$	$L_2$
in	H10	h10	$\pm 0.005$	+0.005-0	+0.004 -0
$\emptyset d_2$ in $\geq$	1.5	2.5	3.5		
	-0.001 -0.003	-0.001 -0.004	-0.001 -0.005		

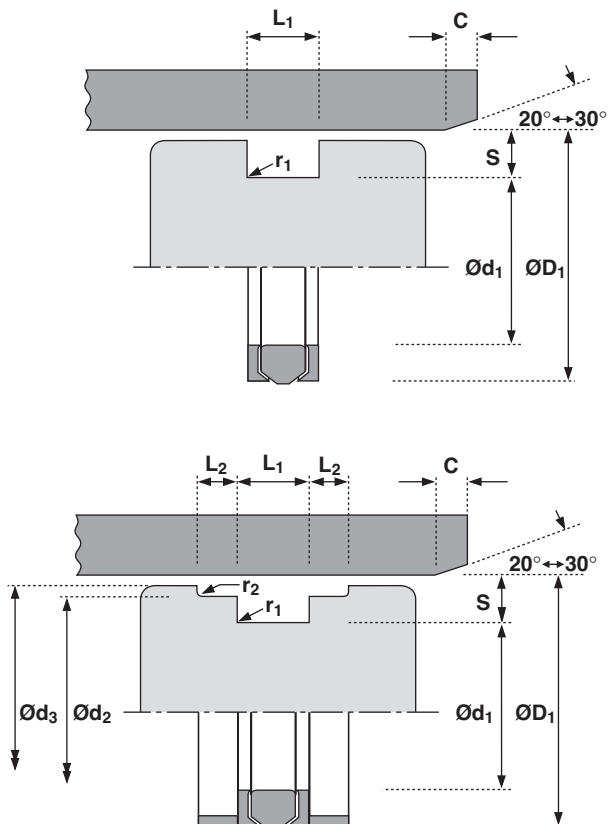
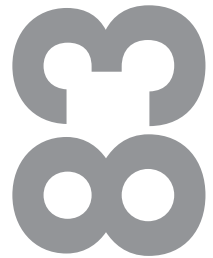

### Design

The Hallite 83 Tri-Seal assembly offers the engineer many advantages when considering the design of cast iron, bronze, alloy etc. one-piece pistons in double-acting hydraulic cylinders, not the least being cost effectiveness with long and efficient seal life.

The Tri-Seal consists of two split plastic anti-extrusion rings and a nitrile synthetic rubber sealing member. Under pressure, the seal exerts a wedging action on the anti-extrusion ring, reducing the clearance between the cylinder bore and the piston, thus minimising the possibility of extrusion of the seal.

Wear rings are also available for this assembly, allowing the designer to benefit from the following advantages :

- Eliminate metal to metal contact in the bore
- One piece steel piston
- Improved alignment for optimum seal life
- Smoother operation

**Note : For availability of sizes not listed please consult your local Hallite sales department.**

When ordering Hallite 83 with wear rings please replace the last digit of the part number as indicated:

Without wear rings	
Last digit of part no.	_____ 0
With wear rings	
Last digit of part no.	_____ 9

83

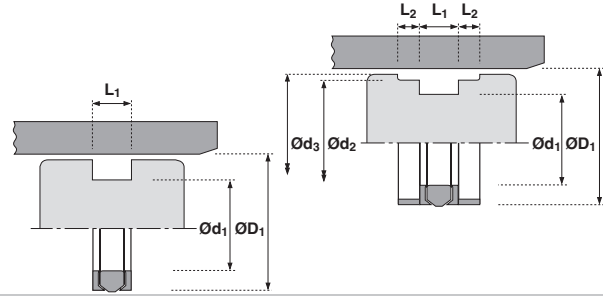

ØD <sub>1</sub>	TOL H10	Ød <sub>1</sub>	TOL h10	Ød <sub>2</sub>	TOL	Ød <sub>3</sub> ±0.005	L <sub>1</sub> + 0.005 - 0	L <sub>2</sub> + 0.004 - 0	PART No.
1.500	+0.004 +0.000	1.125	+0.000 -0.004	1.321	-0.001 -0.003	1.450	0.452	0.250	611191_
2.000	+0.005 +0.000	1.500	+0.000 -0.004	1.821	-0.001 -0.003	1.950	0.587	0.250	232631_
2.500	+0.005 +0.000	2.000	+0.000 -0.005	2.321	-0.001 -0.004	2.450	0.587	0.250	212201_
3.000	+0.005 +0.000	2.500	+0.000 -0.004	2.774	-0.001 -0.004	2.940	0.587	0.250	212211_
3.250	+0.005 +0.000	2.750	+0.000 -0.005	3.023	-0.001 -0.004	3.190	0.587	0.250	232761_
3.500	+0.005 +0.000	3.000	+0.000 -0.005	3.274	-0.001 -0.005	3.440	0.587	0.250	212221_
4.000	+0.005 +0.000	3.250	+0.000 -0.005	3.773	-0.001 -0.005	3.940	0.780	0.250	232641_
4.500	+0.005 +0.000	3.750	+0.000 -0.005	4.232	-0.001 -0.005	4.440	0.780	0.250	236041_
5.000	+0.006 +0.000	4.250	+0.000 -0.005	4.713	-0.001 -0.005	4.910	0.780	0.375	232651_
6.000	+0.006 +0.000	5.250	+0.000 -0.006	5.713	-0.001 -0.005	5.910	0.780	0.375	232661_
7.000	+0.006 +0.000	6.250	+0.000 -0.006	6.673	-0.001 -0.005	6.910	0.780	0.500	236191_
8.000	+0.007 +0.000	7.250	+0.000 -0.007	7.685	-0.001 -0.005	7.910	0.780	0.500	236171_