

659

PISTON SEAL

Single-Acting
Polyurethane, Twin Lip

DESIGN

The Hallite 659 twin lip, asymmetric, single-acting piston seal with precision trimmed sealing lips provides a dry sealing solution in light and medium-duty application. The sealing lips are trimmed at an angle to give optimal rod sealing performance.

The Hallite 659 is designed to have an interference on the piston spigot diameter and has a secondary lip. The secondary sealing lip located behind the primary sealing lip improves stability of the seal in the piston. The outer dynamic lip is shorter and more robust to improving sealing and compression set characteristics over conventional, symmetrical U-rings.

The Hallite 659 is moulded in Hythane® 181, Hallite's high-performance polyurethane, for easy installation and excellent low temperature performance. Depending on tube bore finish, the Hallite 659 is also offered in Hythane® 361 polyurethane.

This seal is for use in single-acting piston seal applications only.

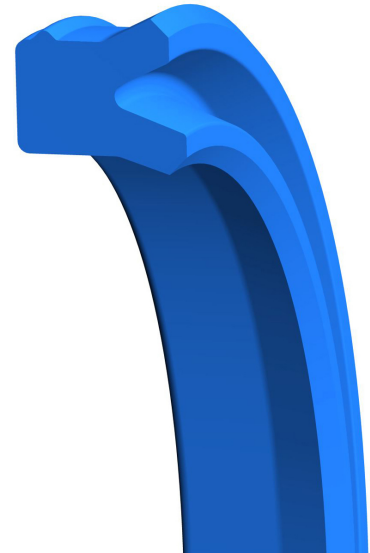

FEATURES

- Robust design
- Excellent wear resistance
- Increase seal stability
- Performs well over wide temperature range and is extremely effective in low temperatures
- Primary lip protection
- Easy to install

MATERIALS

As standard, this product comes in the following material. Contact your local Hallite technical team if you would like to find out if this profile can be made in a custom material to suit your application. For further material details, please refer to the Hallite Material Table.

MATERIAL OPTIONS	Name	Type	Colour
Standard	Hythane® 181	TPU-EU	Blue



TECHNICAL DETAILS

OPERATING CONDITIONS	METRIC	INCH
Maximum Speed	1.0 m/sec	3.0 ft/sec
Temperature Range	-45°C +110°C	-50°F +230°F
Maximum Pressure	400 bar	6000 psi

NOTE

Data given are maximum values and can apply depending on specific application. Maximum ratings of temperature, pressure, or operating speeds are dependent on fluid medium, surface, gap value, and other variables such as dynamic or static service. Maximum values are not intended for use together at the same time, e.g. max temperature and max pressure. Please contact your Hallite technical representative for application support.

MAXIMUM EXTRUSION GAP			
Pressure bar	160	250	400
Maximum Gap mm	0.60	0.50	0.40
Pressure psi	2400	3750	6000
Maximum Gap in	0.024	0.020	0.016

NOTE

Figures show the maximum permissible gap all on one side using minimum rod \varnothing and maximum clearance \varnothing . Refer to Housing Design section.

SURFACE ROUGHNESS	μmRa	μmRz	μmRt	μinRa	μinRz	μinRt
Dynamic Sealing Face $\varnothing D_1$	0.1 - 0.4	1.6 max	4 max	4 - 16	63 max	157 max
Static Sealing Face $\varnothing d_1$	1.6 max	6.3 max	10 max	63 max	250 max	394 max
Static Housing Faces L_1	3.2 max	10 max	16 max	125 max	394 max	630 max

CHAMFERS & RADII				
Groove Section $< S$ mm	4.00	5.00	7.50	10.00
Min Chamfer C mm	3.00	3.50	5.00	6.50
Max Fillet Rad r_1 mm	0.20	0.40	0.80	0.80
Max Fillet Rad r_2 mm	0.40	0.80	1.20	1.20
Groove Section $\leq S$ in	0.125	0.187	0.250	0.500
Min Chamfer C in	0.093	0.093	0.125	0.217
Max Fillet Rad r_1 in	0.008	0.008	0.016	0.032
Max Fillet Rad r_2 in	0.016	0.016	0.032	0.047

TOLERANCES	$\varnothing D_1$	$\varnothing d_1$	L_1
mm	H9	js11	+0.25 -0
in	+0.004 -0	0 -0.002	+0.010 -0

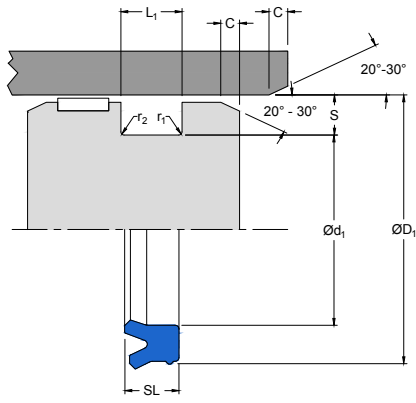

659

PISTON SEAL

Single-Acting
Polyurethane, Twin Lip

PART NUMBER RANGE

METRIC						
ØD ₁	TOL H9 0.00	Ød ₁	TOL js11 -0.08	SL	L ₁ +0.25-0	PART No.
60.00	+0.07 0.00	45.00	+0.08 -0.08	10.00	11.40	4894700
70.00	+0.07 0.00	55.00	+0.10 -0.10	10.00	11.00	4884400
75.00	+0.07 0.00	65.00	+0.10 -0.10	7.30	8.00	4870700
80.00	+0.07 0.00	65.00	+0.10 -0.10	11.50	12.50	4892200‡
90.00	+0.09 0.00	75.00	+0.10 -0.10	11.50	12.50	4775500‡
90.00	+0.09 0.00	80.00	+0.10 -0.10	8.00	9.00	4834000
100.00	+0.09 0.00	80.00	+0.10 -0.10	14.50	16.00	4580300‡
100.00	+0.09 0.00	85.00	+0.11 -0.11	10.00	11.40	4894900
100.00	+0.09 0.00	85.00	+0.11 -0.11	11.50	12.50	4775600‡
105.00	+0.09 0.00	90.00	+0.11 -0.11	11.50	12.50	4892300
110.00	+0.09 0.00	90.00	+0.11 -0.11	14.50	16.00	4580400‡
110.00	+0.09 0.00	95.00	+0.11 -0.11	11.50	12.50	4775700‡
120.00	+0.09 0.00	100.00	+0.11 -0.11	11.80	13.00	4865000
130.00	+0.10 0.00	115.00	+0.11 -0.11	11.50	12.50	4813000

NOTE

Part numbers suffixed by "‡" indicate housing sizes to meet ISO 5597.

